

Engelmann Ultrasonic Thermal Energy Meter

SensoStar U

Ultrasonic heat meter for inline installation points



- Detection of back flow and air
- High temperature resistant for district heating
- Measuring cycle temperature, dynamic: 2 / 60 s
- Detachable calculator unit: 85 cm pulse cable length (2,85 m optional)
- Communication interfaces:
 - wireless M-Bus;
 - wireless M-Bus + 3 pulse inputs;
 - M-Bus;
 - M-Bus + 3 pulse inputs;
 - Modbus RTU;
 - LoRaWAN + 3 pulse inputs;
 - 1 pulse output;
 - 2 pulse outputs

Technical data:

Flow sensor

Measuring method		ultrasonic; time-of-flight										
Sizes	Nominal flow q_p	m ³ /h	0,6	0,6	1,5	1,5	2,5	2,5	3,5	3,5	6,0	10,0
	Low flow threshold	l/h	6	6	6	6	12	12	14	14	30	50
	Minimum flow q_i	l/h	12	12	12	12	25	25	28	28	60	100
	Maximum flow q_s	m ³ /h	1,2	1,2	3,0	3,0	5,0	5,0	7,0	7,0	12,0	20
Pressure drop Δp at q_p		bar	0,03	0,03	0,21	0,04	0,12	0,12	0,21	0,21	0,20	0,11
Pressure drop Δp at q_s		bar	0,13	0,13	0,85	0,17	0,46	0,46	0,89	0,89	0,80	0,43
Nominal diameter		mm	DN 15	DN20	DN15	DN20	DN 20	DN 25	DN 20	DN 25	DN 25	DN 40
Thread		inch	G3/4B	G1B	G3/4B	G1B	G1B	G1 1/4B	G1	G1 1/4B	G1 1/4B	G2B
Length		mm	110	190	110	105; 130; 190	105; 130; 190	260	130; 190	150; 260	150; 260	200
Dynamic range q_i/q_p		-	1:50	1:50	1:125	1:125	1:100	1:100	1:125	1:125	1:100	1:100
Accuracy class (MID)					class 2							
Nominal pressure PN		bar	16									
Temperature range medium heat		°C	15 – 90 15 – 130 high temperature (150; for maximal 2000 h) (optional)									
Temperature range medium cooling (from q_p 1,5 to q_p 10)		°C	5 – 50									
Temperature range medium heat / cooling		°C	15 – 90 heat 15 – 120 high temperature (optional) 5 – 50 cooling									
Point of installation			outlet flow and inlet flow; can be set when the amount of energy is still ≤ 10 kWh									
Mounting position			any position									
Protection class			IP65									

Calculator unit

Temperature range medium	°C	0 – 150 heat 0 – 50 cooling (from q_p 1,5 to q_p 10)
Ambient temperature in the field	°C	5 – 55 at 95 % relative humidity
Transport temperature	°C	-25 – 70 (for maximal 168 h)
Storage temperature	°C	-25 – 55
Temperature difference range $\Delta\theta$ heat	K	3 – 100
Temperature difference range $\Delta\theta$ cooling	K	-3 – -50
Minimum temp. difference $\Delta\theta$ heat	K	> 0,05
Minimum temperature difference $\Delta\theta$ cooling	K	< -0,05
Minimum temperature difference $\Delta\theta_{HC}$ heat / cooling	K	> 0,5 / < -0,5
Resolution temperature	°C	0,01
Measuring cycle temperature; dynamic	s	2 / 60; using a power pack: 2 s permanent
Measuring cycle flow	s	2
Display		LCD - 8 digits + special characters
Decimal places		up to 3 after comma

Units		MWh, kW, m ³ , m ³ /h (kWh, GJ, MMBTU, Gcal); unit of energy can be set when the amount of energy is still ≤ 10 kWh
Interfaces		optical interface (M-Bus protocol); optional: wireless M-Bus; wireless M-Bus + 3 pulse inputs; M-Bus; M-Bus + 3 pulse inputs; Modbus RTU; LoRaWAN + 3 pulse inputs; 1 pulse output; 2 pulse outputs
Power supply		exchangeable 3 V lithium battery; all types prepared for 3 V power pack (input voltage 230 V / 24 V)
Estimated lifetime	years	10 (no option: 1 pulse output); 6+1
Data storage		nonvolatile memory
Reading dates		selectable yearly reading date; 15 monthly and semimonthly values: via display or wireless M-Bus (compact mode); 24 monthly and semimonthly values: via optical interface or M-Bus
2 tariff registers		can be set individually; adding up energy or time
Storage of maximum values		flow, power and temperatures (inlet, outlet, Δθ), plus the respective maximum values of the last 15 months
Protection class		IP65
CE		yes
EMC		EN 1434

Temperature sensors (2-wire technique)

Platinum precision resistor		Pt 1000
Diameter	mm	5; 5,2; 6; AGFW 27,5; 38
Length of cable	m	1,5; 3; 6
Installation		asymmetrical; symmetrical

Dimensions calculator unit

Calculator housing (H x W x D)	mm	75 x 110 x 34,5
--------------------------------	----	-----------------

Dimensions meter

Qp (m ³ /h)	Nominal diameter	G (")	L (mm)	H (mm)	A (mm)	Weight (basic version in kg)
0,6	DN 15	G3/4B	110	65	38,5	0,600
0,6	DN20	G1B	190	65	38,5	0,770
1,5	DN 15	G3/4B	110	65	38,5	0,600
1,5	DN 20	G1B	105	66	39,5	0,650
1,5	DN 20	G1B	130	66	339,5	0,680
1,5	DN 20	G1B	190	65	38,5	0,770
2,5	DN 20	G1B	105	66	39,5	0,650
2,5	DN 20	G1B	130	66	39,5	0,680
2,5	DN 20	G1B	190	66	39,5	0,790
2,5	DN 25	G1 1/4B	260	66	39,5	1,080
3,5	DN 20	G1B	130	66	39,5	0,680
3,5	DN 20	G1B	190	66	39,5	0,790
3,5	DN 25	G1 1/4B	150	66	339,5	0,820
3,5	DN 25	G1 1/4B	260	66	39,5	1,080
6,0	DN 25	G1 1/4B	150	68,5	42	0,820
6,0	DN 25	G1 1/4B	260	68,5	42	1,080
10,0	DN 40	G2B	200	73	46,5	1,530
10,0	DN 40	G2B	300	73	46,5	1,970

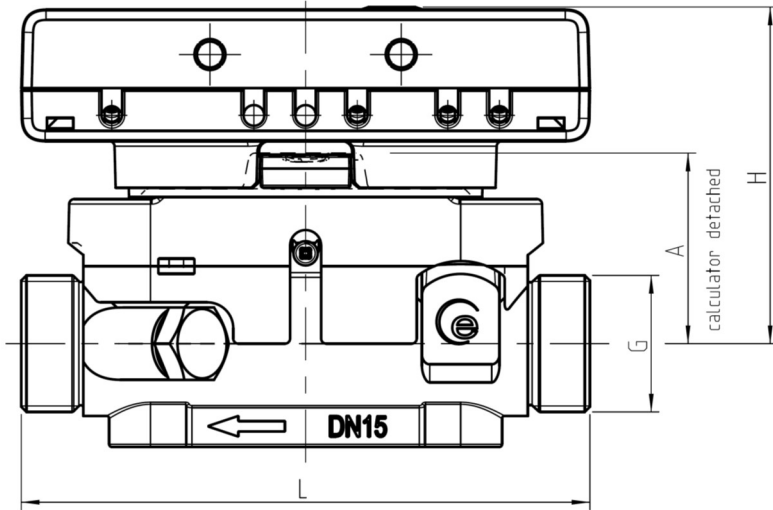

Pressure drop SensoStar U

Pressure drop [mbar]

